

CE

**RF**  
**ROLLFEN**  
**MAKİNA**



**ÜRÜN KATALOĞU**  
**PRODUCT CATALOG**

## **ROLLFORM ÜRETİM HATTI** **ROLLFORMING PRODUCTION LINE**



**ÜRETİMDEKİ ÇÖZÜM ORTAĞINIZ...**  
**YOUR SOLUTION PARTNER FOR PRODUCTION...**

**Türkçe / English**

HAKKIMIZDA 1

---

ABOUT 2

---

PRODUCTION LINE FOR CORNER BEAD PROFILE  
KÖŞE PROFİLLERİ ÜRETİM HATTI 3

---

PRODUCTION LINE FOR GYPSUMBOARD PROFILE  
ALÇIPAN PROFİLLERİ ÜRETİM HATTI 9

---

PRODUCTION LINE FOR GYPSUM ACCESSORIES  
ALÇIPAN PROFİL AKSESUARLARI ÜRETİM HATTI 14

---

QUALITY DOCUMENTS  
KALİTE BELGELERİ 17

---

REFERENCES  
REFERANSLAR 18

---

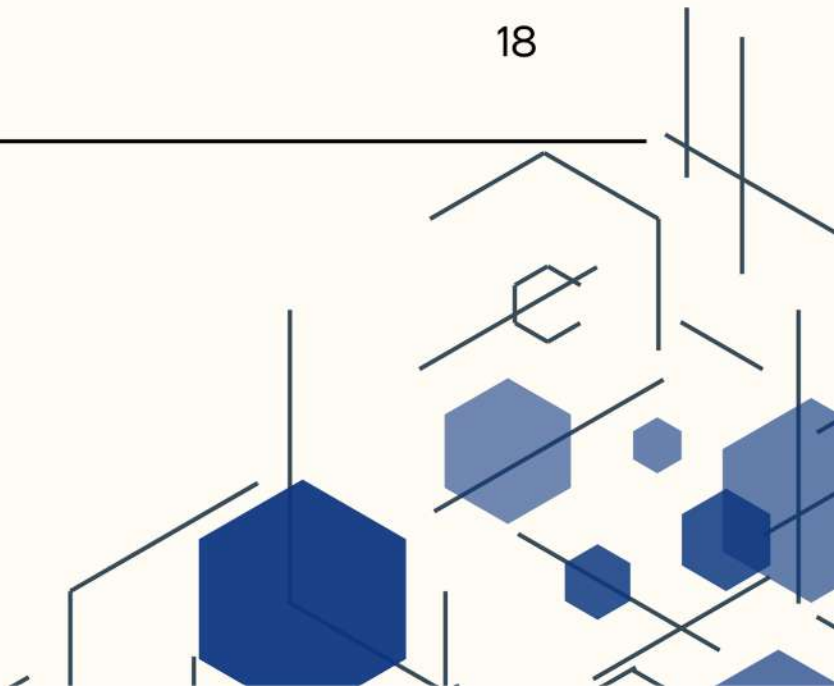

Üretimdeki çözüm ortağınız.

## HAKKIMIZDA

Rollfen, 15 yıllık profesyonel kadrosu ile Profil Üretim Hatları ve Özel Amaçlı makinelerin projelendirilmesi, üretimi ve teknis servisini sunmaktadır.

Standart olarak üretimimizde; Köşe Profili Üretim Hattı (Sıva ve Alçı Köşe Profilleri), Alçıpan Profilleri Üretim Hattı (Tavan, Duvar U, C Profilleri ve Aksesuarları) yer almaktadır. Özel amaçlı olarak, müşterinin talep ettiği özel profili üretecek makine ve ekipmanlarının tasarımı ve üretimi sağlanmaktadır.

Tüm üretim hatlarımız, talebe göre birden fazla profil üretimi yapabilme kabiliyetindedir. Müşteri talebine göre manuel ayarlı, kasetli sistem ya da otomatik olarak tercihe sunulmaktadır.



### • Profesyonel

Deneyimli Kadromuz ile  
Özel Çözümler Üretiyoruz



### • Yaratıcı

Yenilikçi Bir Anlayış ile  
Sonuç Odaklı Çalışıyoruz



### • Zaman

Müşterilerimize Özel Çözümler  
Sunarak İşimizi Planlıyoruz

## TASARIM SÜRECİ ZAMAN ÇİZELGESİ

01

02

03

04

DEĞERLENDİRME  
VE TASARIM  
BRİFİNGİ

KONSEPT VE  
PLANLAMA

TEKNİK  
ÇALIŞMALAR VE  
ÜRETİM

TESLİM

## BİZE ULAŞIN



Merkez: +90 312 512 28 49 / +90 539 233 74 70  
Satış: +90 534 655 25 19 / +90 534 297 00 72



rollfen@rollfenmakina.com  
satis@rollfenmakina.com



<https://www.rollfenmakina.com>



Ankara/TÜRKİYE



Your solution partner for production.

## ABOUT

As Rollfen, with our professional staff and 15 years of experience, we offer you project design, production, and technical service for roll forming lines and purpose-made machinery.

Our standard production includes Cornerbead Production Line (Plasterboard and Gypsumboard Profiles) and Gypsumboard Production Line (Ceiling, Wall U,C Profiles and accessory). We provide purpose-made machine equipment design and customized production according to the special profile demands of our customers.

As per your demand, our all production lines are capable of producing multiple profiles and adjustments are optional as manual, cassette system, and automatic.



### • Professional

We provide special solutions with our experienced staff



### • Creative

We work result oriented with an innovative approach



### • Time

We plan our work by providing special solutions to our customers

## DESIGN PROCESS TIMELINE

01

EVALUATION AND  
DESIGN BIREFFING

02

CONCEPT AND  
PLANNING

03

TECHNICAL  
STUDIES AND  
PRODUCTION

04

DELIVERY

## CONTACT US



Center:+90 312 512 28 49 / +90 539 233 74 70  
Sales:+90 534 655 25 19 / +90 534 297 00 72



rollfen@rollfenmakina.com  
satis@rollfenmakina.com



<https://www.rollfenmakina.com>



Ankara/TURKEY



# PRODUCTION LINE FOR CORNER BEAD PROFILE KÖŞE PROFİLLERİ ÜRETİM HATTI

**RF**  
ROLLFEN  
MAKİNA

Üretimdeki çözüm ortağınız.

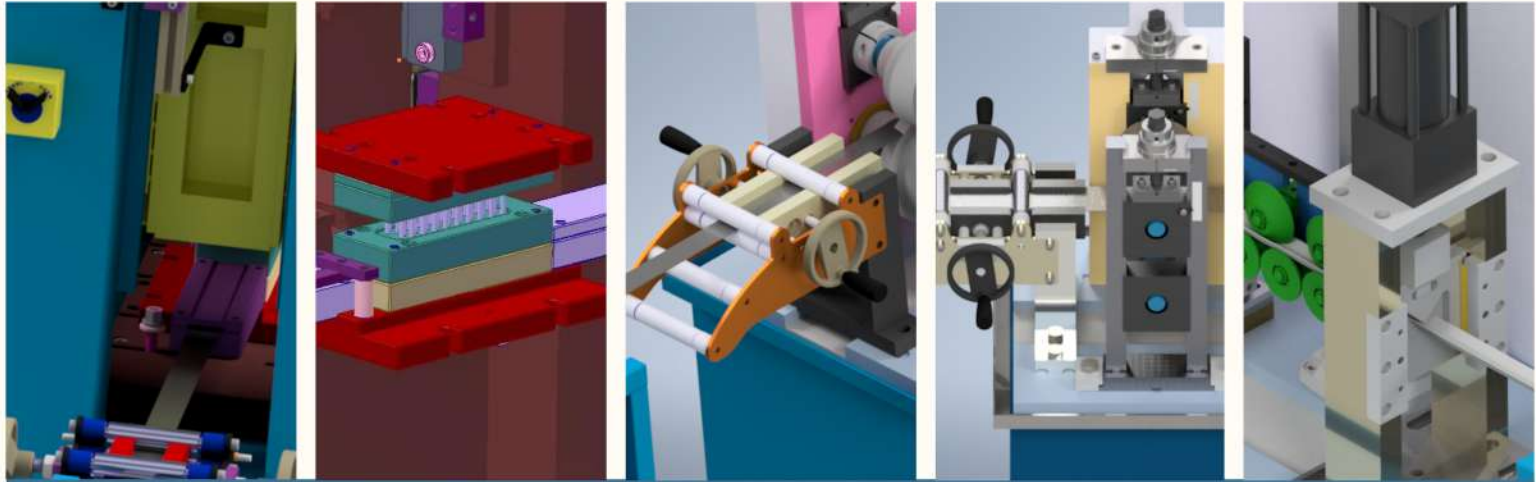
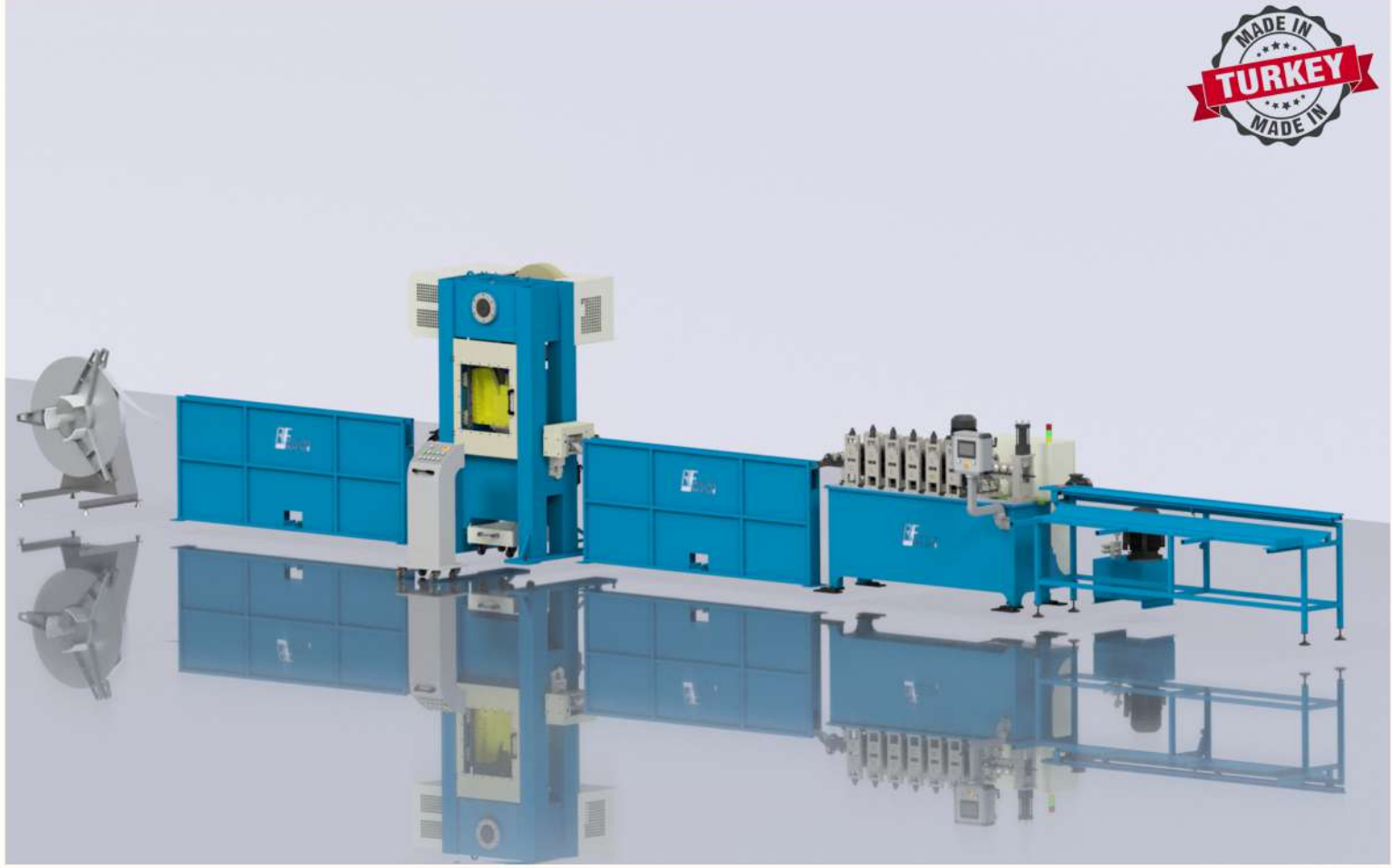

## PRODUCTION LINE FOR CORNER BEAD PROFILE SPECIFICATIONS / KÖŞE PROFİLİ ÜRETİM HATTI ÖZELLİKLERİ

Production Speed / Üretim Hızı	24m/min - 35 m/min
Material Thickness / Malzeme Kalınlığı	0,30mm - 0,50 mm
Roll Width / Rulo Genişliği	20 mm - 100 mm
Production Line Area (Width x Length) / Üretim Hattı Alanı (Genişlik x Uzunluk)	2,5 m x 15 m
Total Energy Consumption / Toplam Enerji Tüketimi	16 kW
Malzeme / Material	Galvanized Sheet /Galvanizli Sac (DX51)

## PRODUCTS / ÜRÜNLER

PRODUCTS / ÜRÜNLER	
1	Perforated Angle Bead / Delikli Alçı Köşe Profili
2	Architrave Bead / Fugalı Pervaz Profili
3	Squared Corner Bead/ Bükülebilir Köşe Profili
4	ANO Profile/ Master Profili
5	Expanded Mesh / Kaba Sıva Profili
6	Plaster Stop / Sıva Etek Profili



1

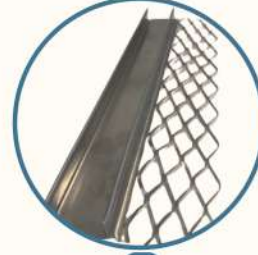

2



3



4

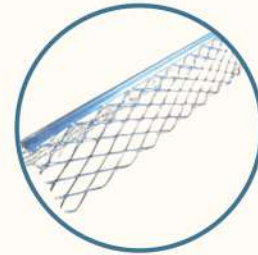

5



6

## ROLL DE-COILER / RULO SAC AÇICI

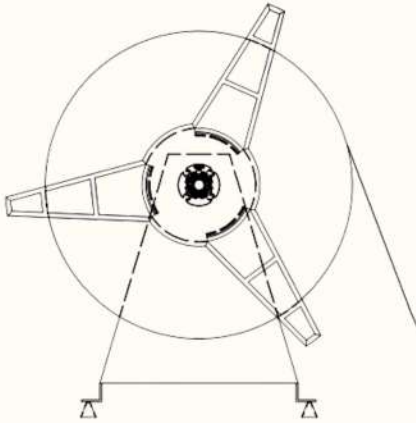

	Roll Weight / Rulo Ağırlığı (kg)	Roll Width / Rulo Geniřlięi (mm)	Power / Güç (kW)	Roll Inner Diameter / Rulo İç Çap (mm)	Roll Outer Diameter / Rulo Dış Çap (mm)
Roll De-coiler / Rulo Sac Açıcı	1250	300	0.75	400-550	1200

## ECCENTRIC PRESS / EKSANTRİK PRES

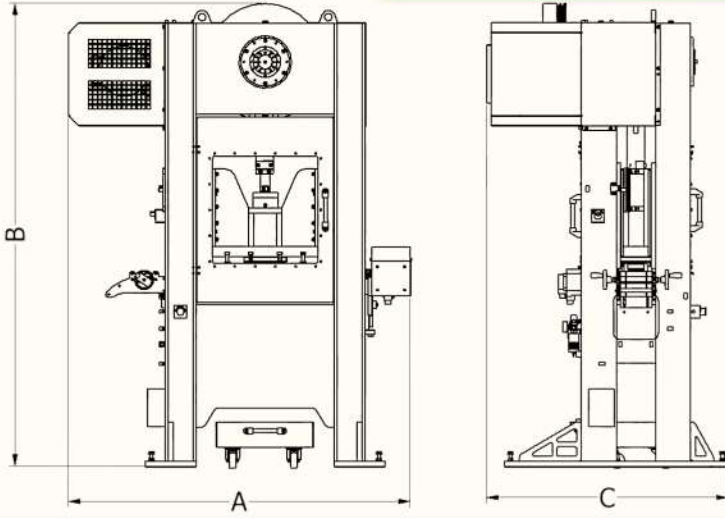

### ECCENTRIC PRESS TECHNICAL SPECIFICATIONS / EKSANTRİK PRES TEKNİK ÖZELLİKLERİ

Width / Genişlik (C) ( mm )	1250
Length / Uzunluk (A) ( mm )	1760
Height / Yükseklik (B) ( mm )	2380
Weight / Ağırlık ( kg )	2500
Power / Güç (kW)	5.5
Stroke / Strok (mm)	24
Number Of Strikes / Vuruş Sayısı (per a minute /dakikada)	300

## PROFILE CHANNELS / PROFİL KANALLARI

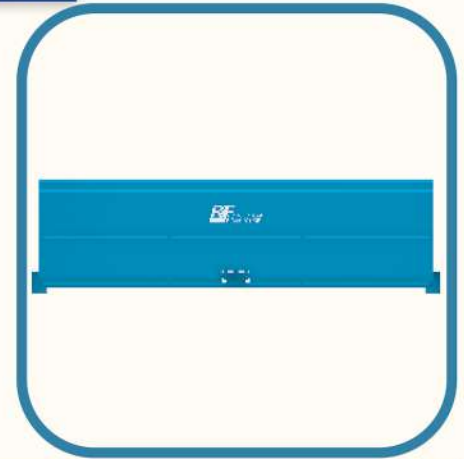
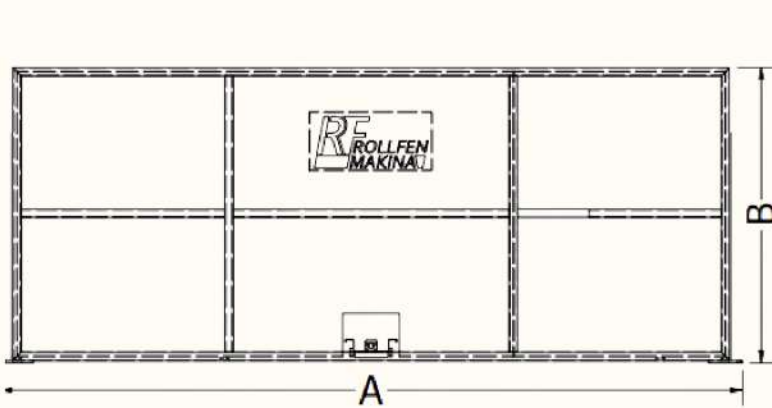

### SMALL PROFILE CHANNEL TECHNICAL SPECIFICATIONS / KÜÇÜK PROFİL KANAL TEKNİK ÖZELLİKLERİ

Width / Genişlik (C) ( mm )	220
Length / Uzunluk (A) ( mm )	2500
Height / Yükseklik (B) ( mm )	1040

### BIG PROFILE CHANNEL TECHNICAL SPECIFICATIONS / BÜYÜK PROFİL KANAL TEKNİK ÖZELLİKLERİ

Width / Genişlik (C) ( mm )	220
Length / Uzunluk (A) ( mm )	3000
Height / Yükseklik (B) ( mm )	1040

## ROLL FORM MACHINE / ROLL FORM MAKİNESİ

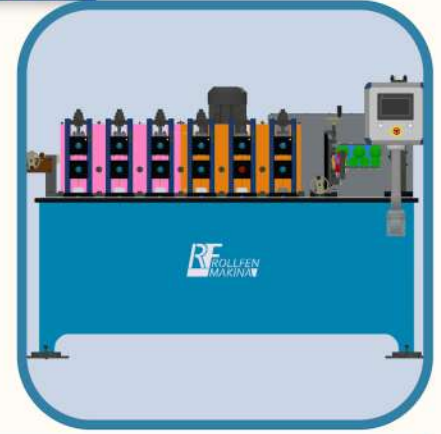
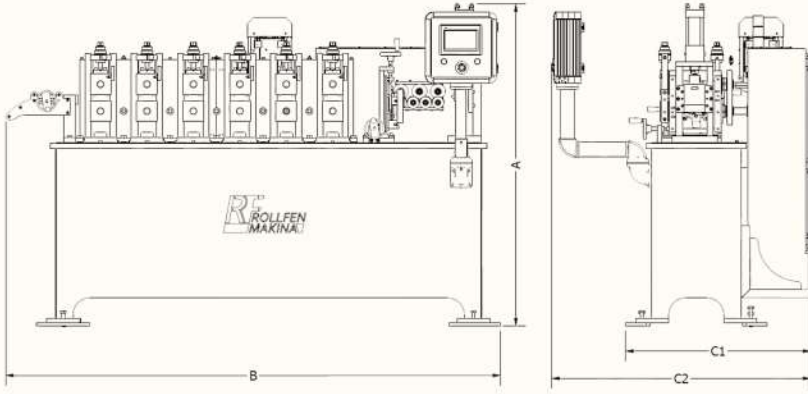

### ROLL FORM MACHINE TECHNICAL SPECIFICATIONS / ROLLFORM MAKİNESİ TEKNİK ÖZELLİKLERİ

Width / Genişlik (C1) ( mm )	900
Width / Genişlik (C2) ( mm )	1300
Length / Uzunluk (B) ( mm )	2400
Height / Yükseklik (A) ( mm )	1560
Weight / Ağırlık ( kg )	1200
Power / Güç (kW)	4
Reducer / Redüktör	EV 080-10L/4a
Exchange Ratio / Çevrim Oranı	13,25
Output Speed / Çıkış Devri (rpm)	110

## WORK-OUT TABLE / ÇALIŞMA MASASI

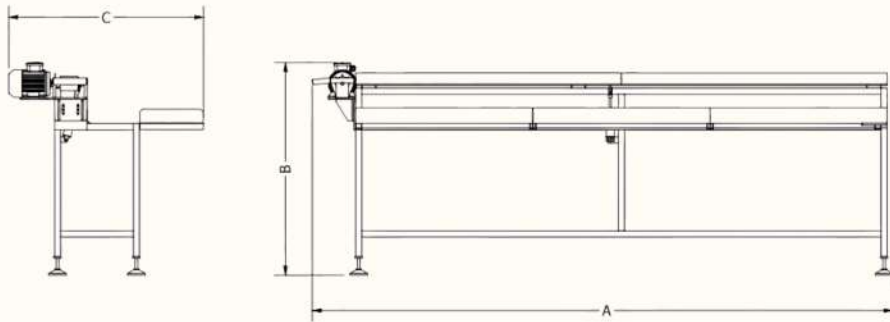

### WORK-OUT TABLE TECHNICAL SPECIFICATIONS / ÇALIŞMA MASASI TEKNİK ÖZELLİKLERİ

Width / Genişlik (C) ( mm )	1110
Length / Uzunluk (A) ( mm )	3280
Height / Yükseklik (B) ( mm )	1130
Power / Güç (kW)	0,37
Output Speed / Çıkış Devri (rpm)	1000



## SPECIFICATION OF SAMPLE PRODUCTS / ÖRNEK ÜRÜNLERİN ÖZELLİKLERİ

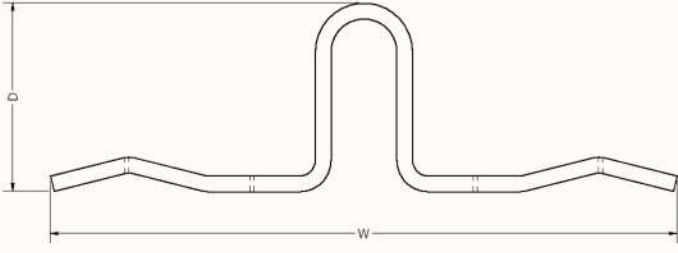

### ANO Profile / Mastar Profili

W	20
D	6
Material / Malzeme	Galvanized steel / Galvanizli Çelik

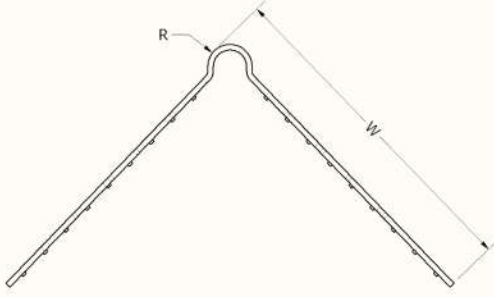

### Perforated Angle Bead / Alçı Delikli Köşe Profili

W	20
R	2
Material / Malzeme	Galvanized steel / Galvanizli Çelik -Aluminum/Alüminyum

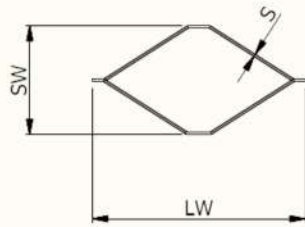
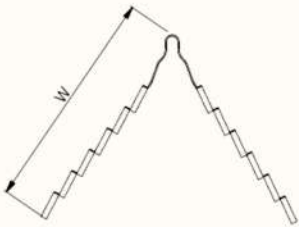

### Expanded Mesh / Kaba Sıva Profili

Wing Length / Kanat Uzunluğu (W)	35
Window Size As Per Customer Request / Müşteri İsteğine Göre Pencere Boyutu	LW x SW x S
Material / Malzeme	Galvanized steel / Galvanizli Çelik Stainless Steel 304 L / Paslanmaz Çelik 304 L

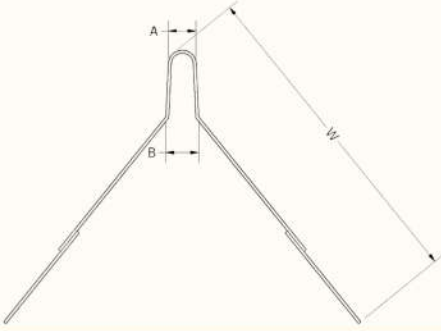

**Squared Corner Bead / Bükülebilir Köşe Profili**

W	49.67
A	4.25
B	5.00
Material / Malzeme	Galvanized steel / Galvanizli Çelik

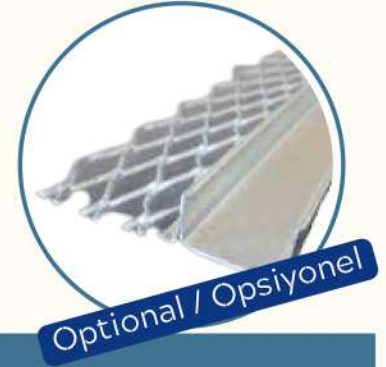
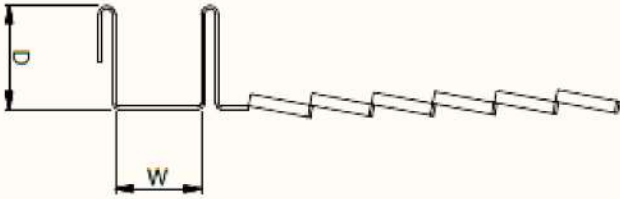

**Architrave Bead / Fugalı Pervaz Profili**

W	10 - 13 mm / 16 - 19 mm
D	12
Material / Malzeme	Galvanized steel / Galvanizli Çelik Stainless Steel 304 L / Paslanmaz Çelik 304 L

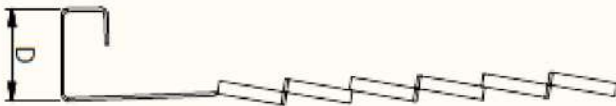

**Plaster Stop / Sıva Etek Profili**

D	10 - 13 mm / 16 - 19 mm
Material / Malzeme	Galvanized steel / Galvanizli Çelik Stainless Steel 304 L / Paslanmaz Çelik 304 L



Dimensions of rollform machine and press may vary in the optional products. / Pres ve Rollform makinesinin ölçüleri opsiyonel ürünlerde değişiklik gösterebilir.

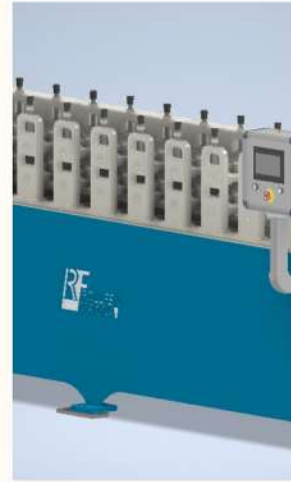
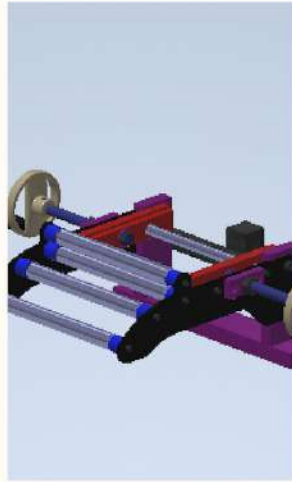
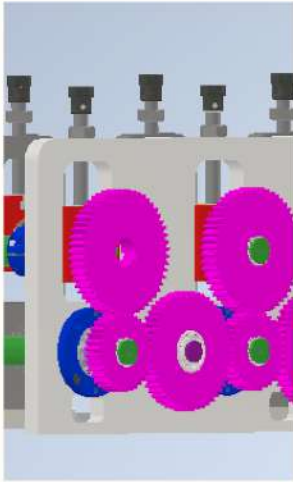
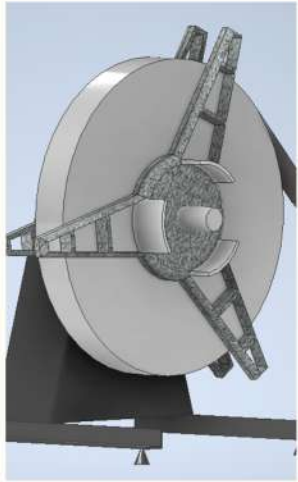
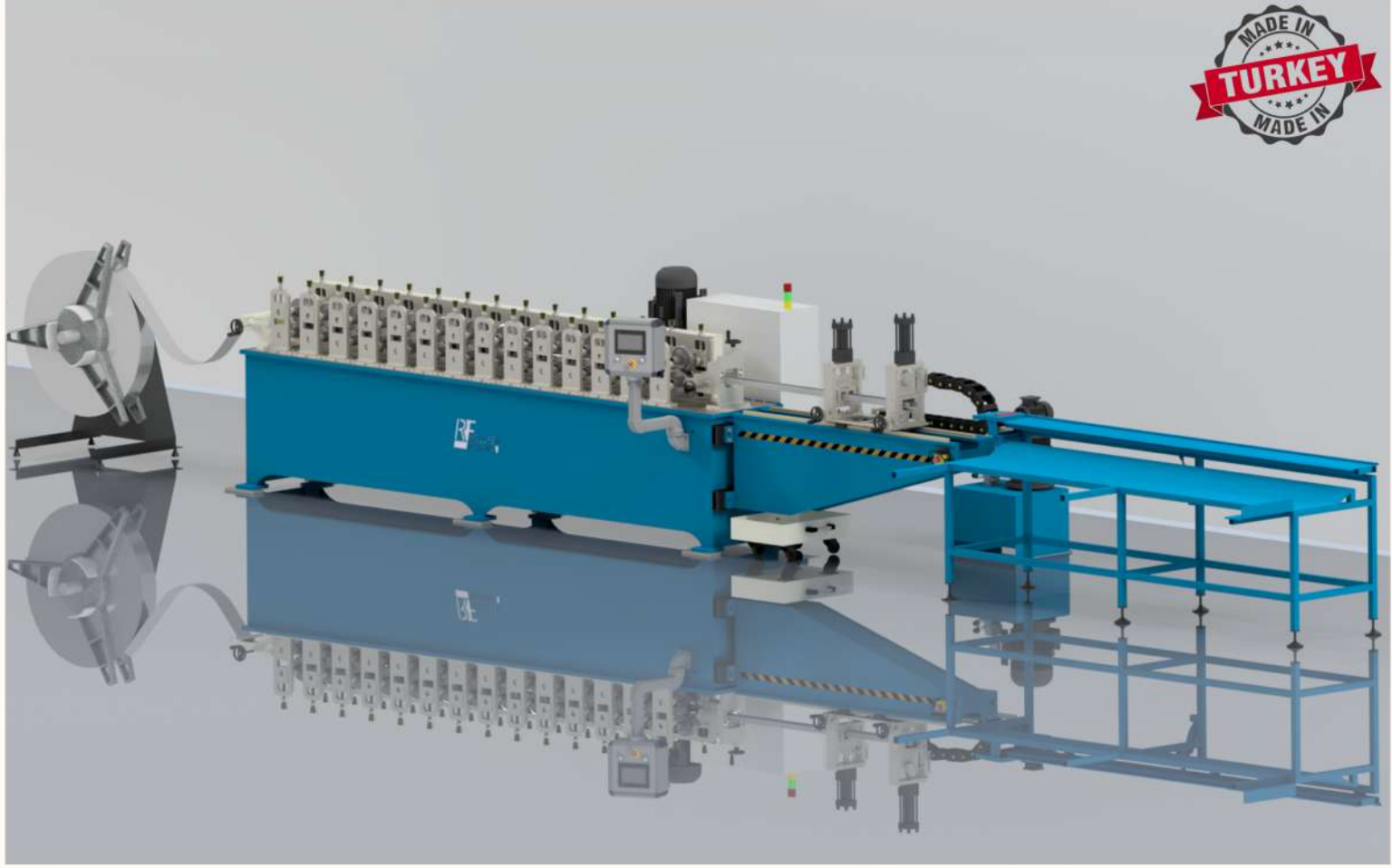

PRODUCTION LINE FOR GYPSUMBOARD PROFILE TECHNICAL SPECIFICATIONS / ALÇIPAN PROFİL ÜRETİM HATTI TEKNİK ÖZELLİKLERİ

Üretim Hızı / Production Speed	60 m/min (max.)
Material Thickness / Malzeme Kalınlığı	0,30 mm - 0,60 mm
Roll Width / Rulo Geniřlięi	20 mm - 197 mm
Production Line Area (Width x Length) / Üretim Hattı Alanı (Geniřlik x Uzunluk)	2 m x 15 m
Total Energy Consumption / Toplam Enerji Tüketimi	15 kW
Malzeme / Material	Galvanized Sheet /Galvanizli Sac (DX51)

## PRODUCTS / ÜRÜNLER

PRODUCTS / ÜRÜNLER	
1	Duvar C / CW-Stud
2	Duvar U / UW- Track
3	Tavan C / CD - Stud Channel
4	Tavan U / UD - Main Channel
5	Omega / Omega Furring Channel
6	Fourrure

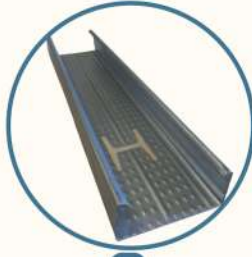

1

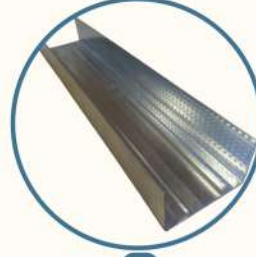

2

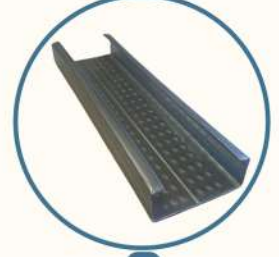

3



4

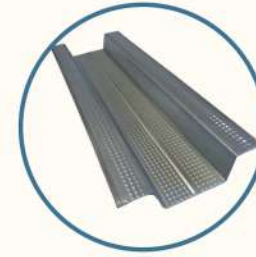

5



6

## ROLL DE-COİLER / RULO SAC AÇICI

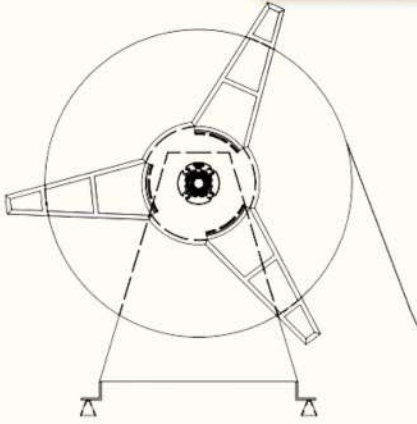

	Roll Weight / Rulo Ağırlığı (kg)	Type	Roll Widtht Rulo Genişliği (mm)	Roll Inner Diameter / Rulo İç Çap (mm)	Roll Outer Diameter / Rulo Dış Çap (mm)
Roll De-coiler / Rulo Sac Açıcı	2500	It is non-motorized and brake type. / Motorsuz ve Frenli tiptedir.	300	400-550	1200

Üretimdeki çözüm ortağınız.

## ROLL FORM MACHINE / ROLL FORM MAKİNESİ

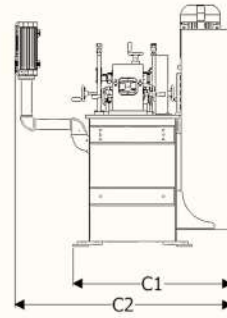
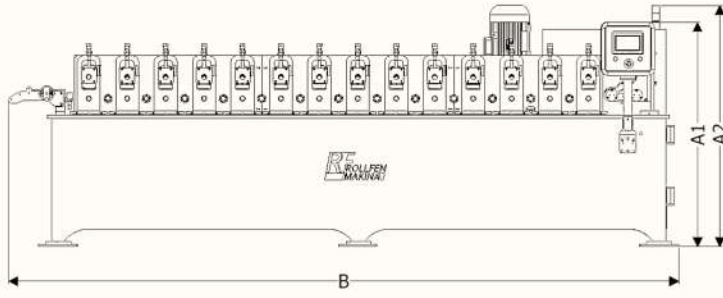

### ROLL FORM MACHINE TECHNICAL SPECIFICATIONS / ROLLFORM MAKİNESİ TEKNİK ÖZELLİKLERİ

Width / Genişlik (C1) ( mm )	1030
Width / Genişlik (C2) ( mm )	1410
Length / Uzunluk (B) ( mm )	4360
Height / Yükseklik (A1) ( mm )	1460
Height / Yükseklik (A2) ( mm )	1570
Weight / Ağırlık ( kg )	3150
Power / Güç (kW)	5.5
Reducer / Redüktör	KR373.003E132S4C
Exchange Ratio / Çevrim Oranı	10.60
Output Speed / Çıkış Devri (rpm)	138

## FLYING SHEARS / UÇAR MAKASLAR

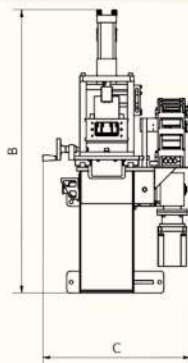
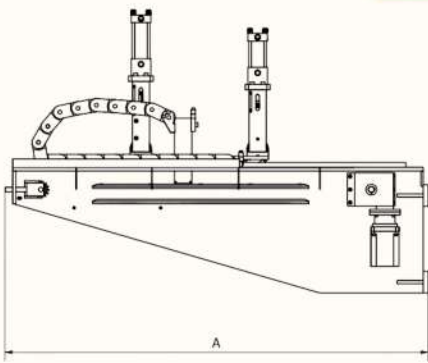

### FLYING SHEARS TECHNICAL SPECIFICATIONS / UÇAR MAKASLAR KANAL TEKNİK ÖZELLİKLERİ

Width / Genişlik (C) ( mm )	690
Length / Uzunluk (B) ( mm )	1310
Height / Yükseklik (A) ( mm )	1960
Weight (kg)	400
Power (kW)	2

**WORK-OUT TABLE / ÇALIŞMA MASASI**

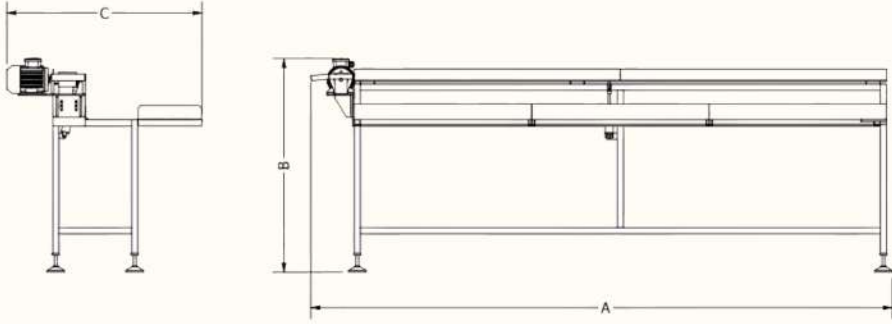

**WORK-OUT TABLE TECHNICAL SPECIFICATIONS / ÇALIŞMA MASASI TEKNİK ÖZELLİKLERİ**

Width / Genişlik (C) ( mm )	1420
Length / Uzunluk (A) ( mm )	3310
Height / Yükseklik (B) ( mm )	1150
Power / Güç (kW)	0,37
Output Speed / Çıkış Devri (rpm)	1000

**SPECIFICATION OF SAMPLE PRODUCTS / ÖRNEK ÜRÜNLERİN ÖZELLİKLERİ**

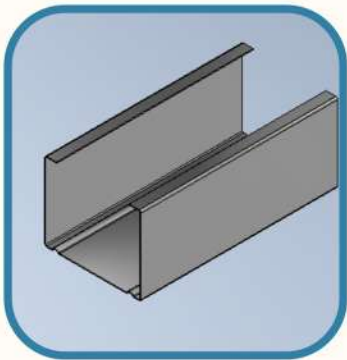

**Duvar C / (CW) Stud**

Material / Malzeme Galvanized steel / Galvanizli Çelik

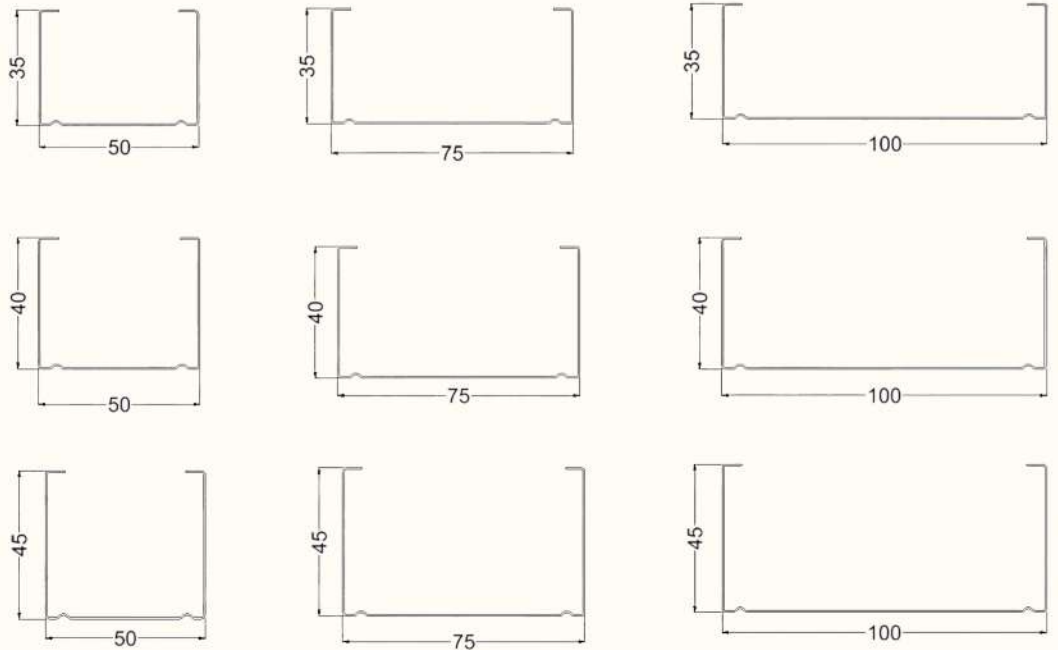

Üretimdeki çözüm ortağınız.

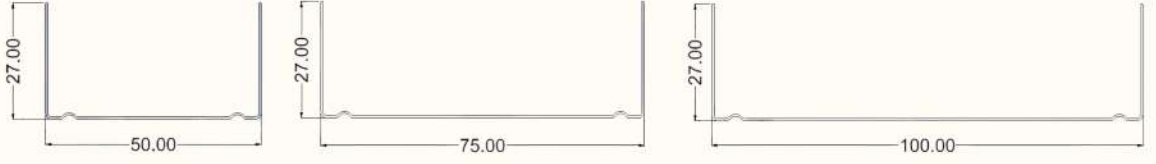
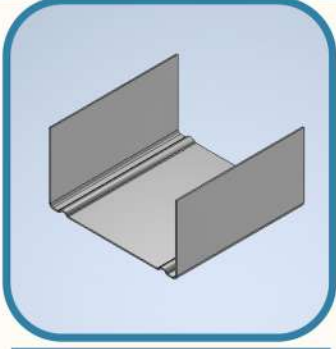

**Duvar U / (UW) Track**

Material /  
Malzeme Galvanized steel /  
Galvanizli Çelik

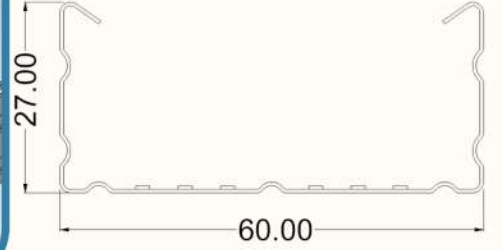
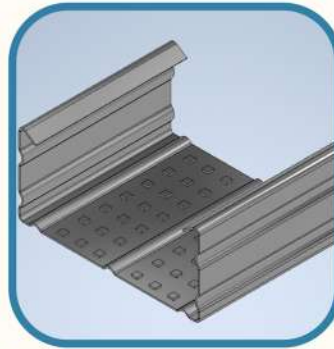
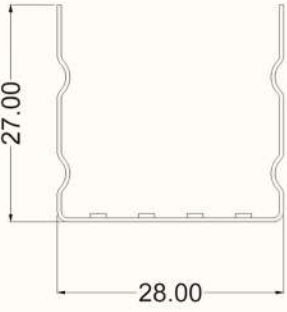

**Tavan U / (UD) Main Track**

Material /  
Malzeme Galvanized steel /  
Galvanizli Çelik

**Tavan C / (CD) Stud Channel**

Material /  
Malzeme Galvanized steel /  
Galvanizli Çelik

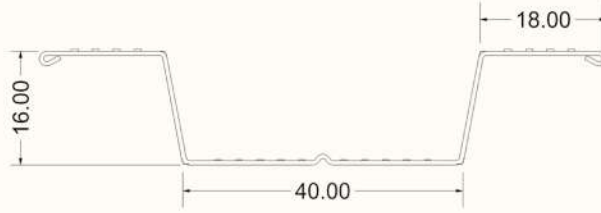

**Omega / Omega Furring Channel**

Material /  
Malzeme Galvanized steel /  
Galvanizli Çelik

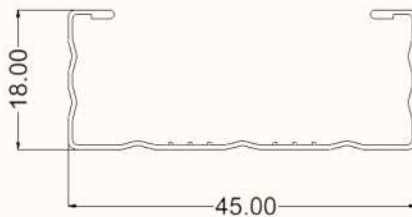
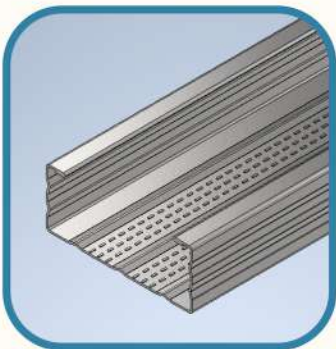

**Fourrure**

Material /  
Malzeme Galvanized steel /  
Galvanizli Çelik

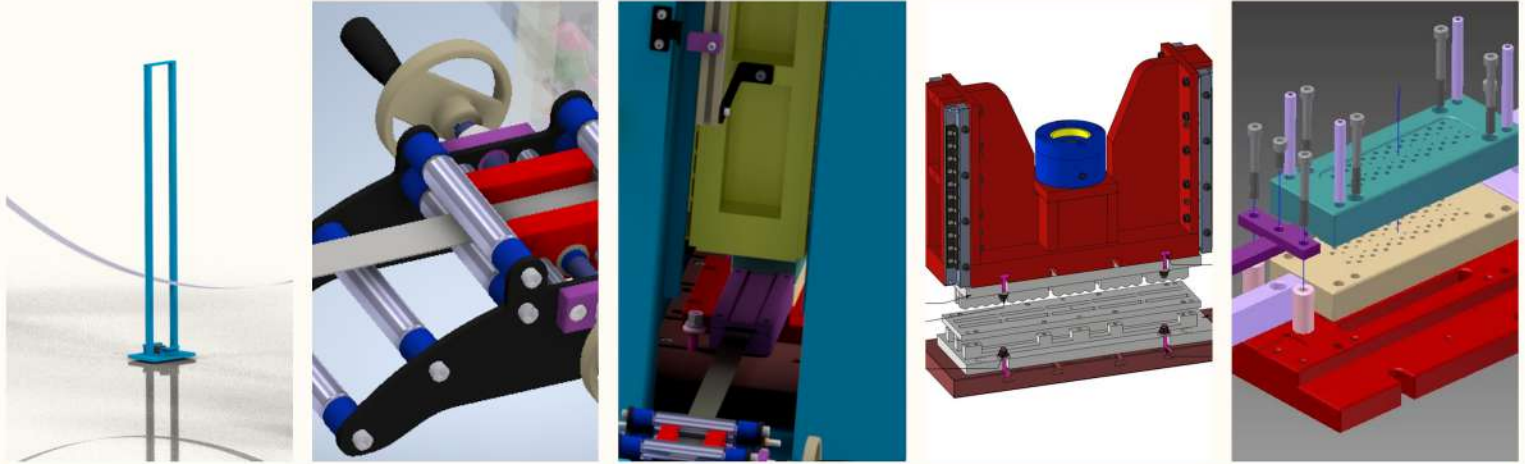
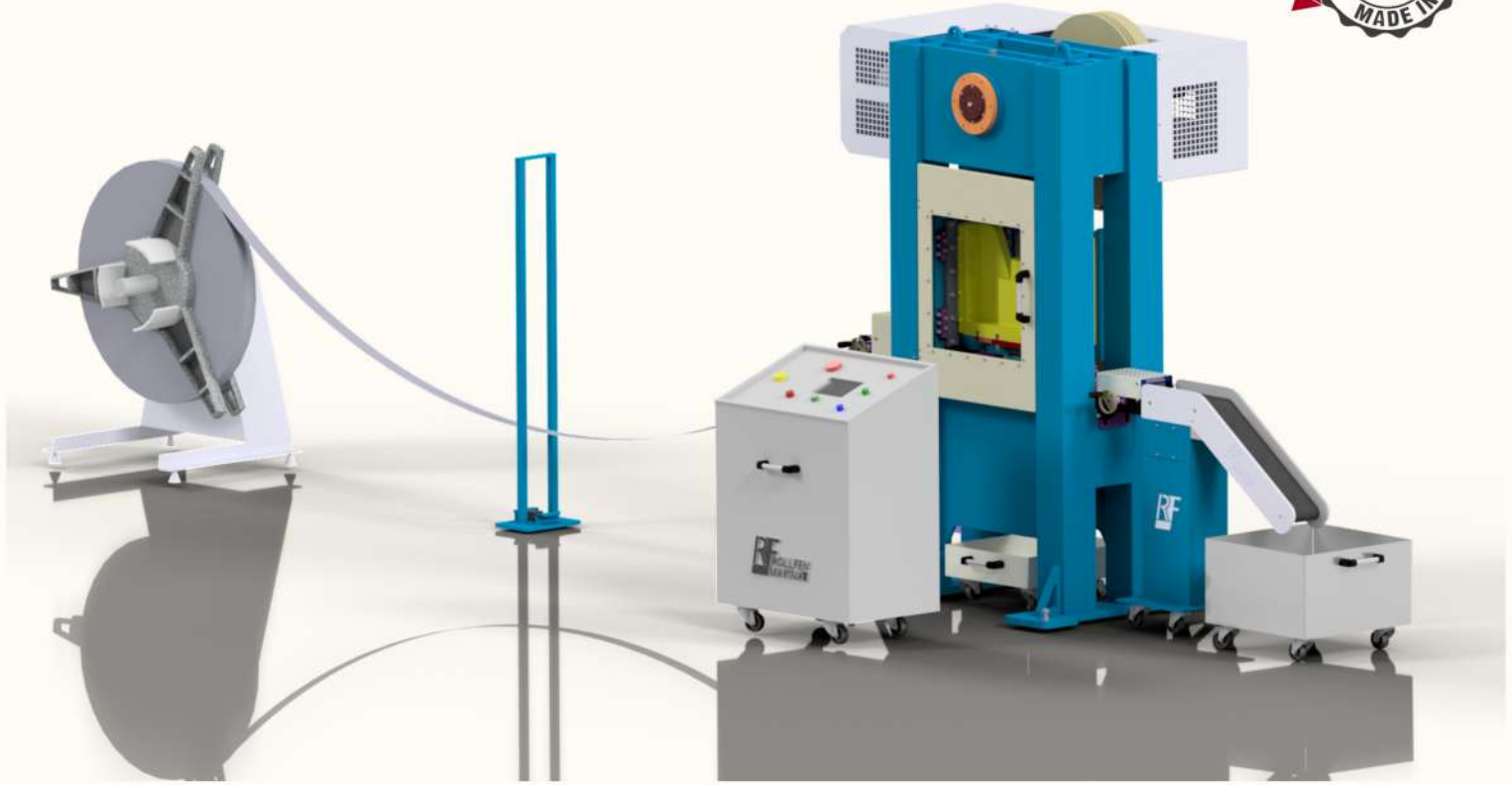
**PRODUCTION LINE FOR ACCESSORY PROFILE TECHNICAL SPECIFICATIONS / AKSESUAR PROFİL ÜRETİM HATTI TEKNİK ÖZELLİKLERİ**

Vuruş Sayısı / Strikes of Number	250
Material Thickness / Malzeme Kalınlığı	0,30 mm - 0,90 mm
Roll Width / Rulo Geniřlięi	20 mm - 100 mm
Production Line Area (Width x Length) / Üretim Hattı Alanı (Geniřlik x Uzunluk)	2 m x 8m
Total Energy Consumption / Toplam Enerji Tüketimi	9 kW
Malzeme / Material	Galvanized Sheet / Galvanizli Sac (DX51)



Üretimdeki çözüm ortağınız.

## ROLL DE-COİLER / RULO SAC AÇICI

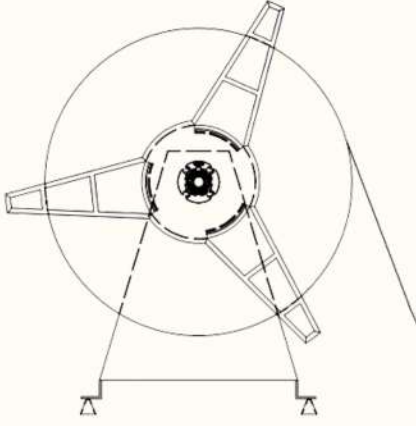

	Roll Weight / Rulo Ağırlığı (kg)	Roll Width / Rulo Geniřliđi (mm)	Power / Güç (kW)	Roll Inner Diameter / Rulo İç Çap (mm)	Roll Outer Diameter / Rulo Dış Çap (mm)
Roll De-coiler / Rulo Sac Açıcı	1250	300	0.75	400-550	1200

## SENSOR BRACKET / SENSÖR KAİDESİ

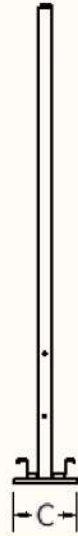
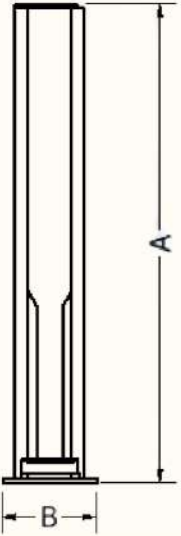

### SENSOR BRACKET TECHNICAL SPECIFICATIONS / SENSÖR KAİDESİ TEKNİK ÖZELLİKLERİ

Width / Geniřlik (C) ( mm )	200
Length / Uzunluk (B) ( mm )	300
Height / Yükseklik (A) ( mm )	1525

## ECCENTRIC PRESS / EKSANTRİK PRES

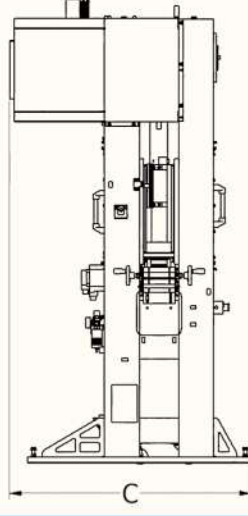
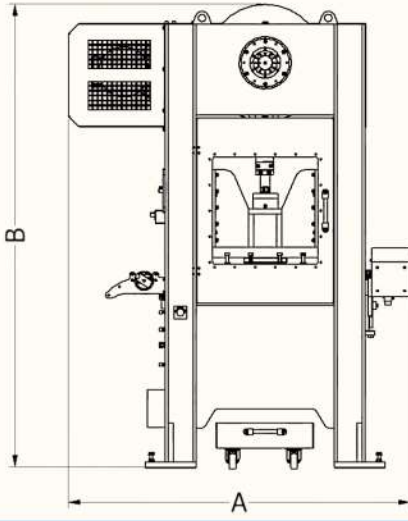

### ECCENTRIC PRESS TECHNICAL SPECIFICATIONS / EKSANTRİK PRES TEKNİK ÖZELLİKLERİ

Width / Genişlik (C) ( mm )	1250
Length / Uzunluk (A) ( mm )	1760
Height / Yükseklik (B) ( mm )	2380
Weight / Ağırlık ( kg )	2500
Power / Güç (kW)	5.5
Stroke / Strok (mm)	24
Number Of Strikes / Vuruş Sayısı (per a minute/dakikada)	250

PRODUCTS / ÜRÜNLER		MATERIAL/ MALZEME
1	Agraf / CD Bracket	Galvanized steel / Galvanizli Çelik
2	Askı Maşası / Profile Hanger Tongs	Galvanized steel / Galvanizli Çelik
3	Klips / Profile Clip	Galvanized steel / Galvanizli Çelik



1



2



3

Üretimdeki çözüm ortağınız.

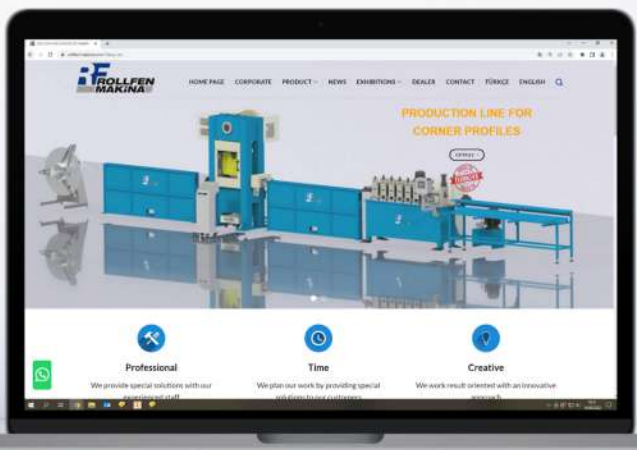



Turkey / Türkiye

Italy/İtalya

Poland/Polonya

Bosnia and Herzegovina / Bosna Hersek

Georgia / Gürcistan

Azerbaijan/Azərbaycan

Uzbekistan / Özbekistan

Iraq / Irak

Palestine / Filistin

Algeria / Cezayir

Morocco / Fas

Nigeria / Nijerya

Cote d'Ivoire / Fildişi Sahili



Merkez / Center: +90 312 512 28 49 / +90 539 233 74 70  
Satış / Sales: +90 534 655 25 19 / +90 534 297 00 72



rollfen@rollfenmakina.com  
satis@rollfenmakina.com



<https://www.rollfenmakina.com>

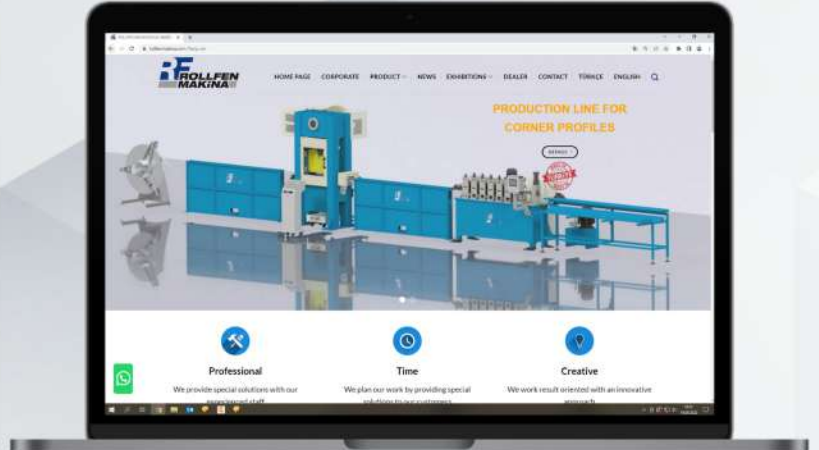

**ÜRETİMDEKİ ÇÖZÜM ORTAĞINIZ...  
YOUR SOLUTION PARTNER FOR PRODUCTION...**